

METAL MAN[®]

Inverter 80

OPERATING MANUAL



Read carefully and understand RULES FOR SAFE OPERATION and instructions before operating. Failure to follow the safety rules and other basic precautions may result in serious personal injury.

Please read and save these instructions. Read through this owner's manual carefully before using product. Protect yourself and others by observing all safety information, warnings, and cautions. Failure to comply with instructions could result in personal injury and/or damage to product or property. Please retain instructions for future reference.

Welding

Description

The Inverter 80 is a portable DC inverter arc welder . This unit uses 120V (110-120V), 60HZ AC power. A 20 amp time delay fuse or circuit breaker is recommended. The ST80i is ideal for Do-It-Yourself projects or for light maintenance. Stick weld carbon steel, stainless steel .TIG weld steel and stainless steel with optional TIG torch.



Unpacking

- 1.1 Remove cartons, bags or Styrofoam containing the welder and accessories.
- 1.2 Check the contents with the packing list below.

ITEM	QTY.
Portable Arc Welder	1 unit
Welding cable with electrode holder	1pc
Grounding cable with earth clamp	1pc
Operator's Manual	1set
Carry strap	1pc

- 1.3 After unpacking unit, inspect carefully for any damage that may have occurred during transit. Check for loose, missing, or damaged parts. Shipping damage claim must be filed with carrier.

Operating Instructions and Parts Manual

Specifications and Dimension

MODEL	Inverter 80
Power supply (v)	1ph-120V-60HZ
No-load voltage (v)	75V
Output Range (A)	20-75A 90A Peak
Duty cycle (%)	20% @75A
Suggested electrode	E6013,E7014,E7018, Stainless steel
Electrode Diameter (Inch)	1/16", 5/64", 3/32" (1.6mm, 2.0mm, 2.4mm)
Dimensions Length x Width x Height	300x120x240MM / 12x5x9 inches
Weight (lbs)	4.5Kgs 9.9Lbs

Know your Welder**Indicating Light** (Power, Thermal Protection)

There are two indicating lights : power indicator and thermal indicator. When the machine is turned on, the power indicator will be on. When the thermal indicator is on, it shows the machine is overloaded and the internal temperature is too high. Weld output will turn off automatically but the fan will still be working. Allow the fan to cool the unit. When the internal temperature is decreased, the overload light will turn off and the machine will be ready to weld.

Current Adjustment

Current adjustment is on the front panel of machine. It is an infinite current output adjustment

Output “+”Connector

This is the connector for electrode holder welding cable most often when STICK welding. When this machine is used for TIG welding, this connector is for the grounding cable.

Ground Cable and Clamp

Operating Instructions and Parts Manual

The ground cable and clamp is attached to the work piece to complete the flow of current needed to weld.

Welding Cable and Electrode Holder

One end of cable is connected to output connectors of the machine. The electrode is clamped in the electrode holder for welding.

Output “-” Connector

This is the connector for grounding cable when STICK welding. When this machine is used for TIG welding, this connector is for the TIG torch

Power Cord

The power cord connects the welder to the 110-120v volt power supply. Plug the 15 amp plug into a 115 volt/20 amp receptacle to supply power to the welder

Wiring Diagrams

Operating Instructions and Parts Manual

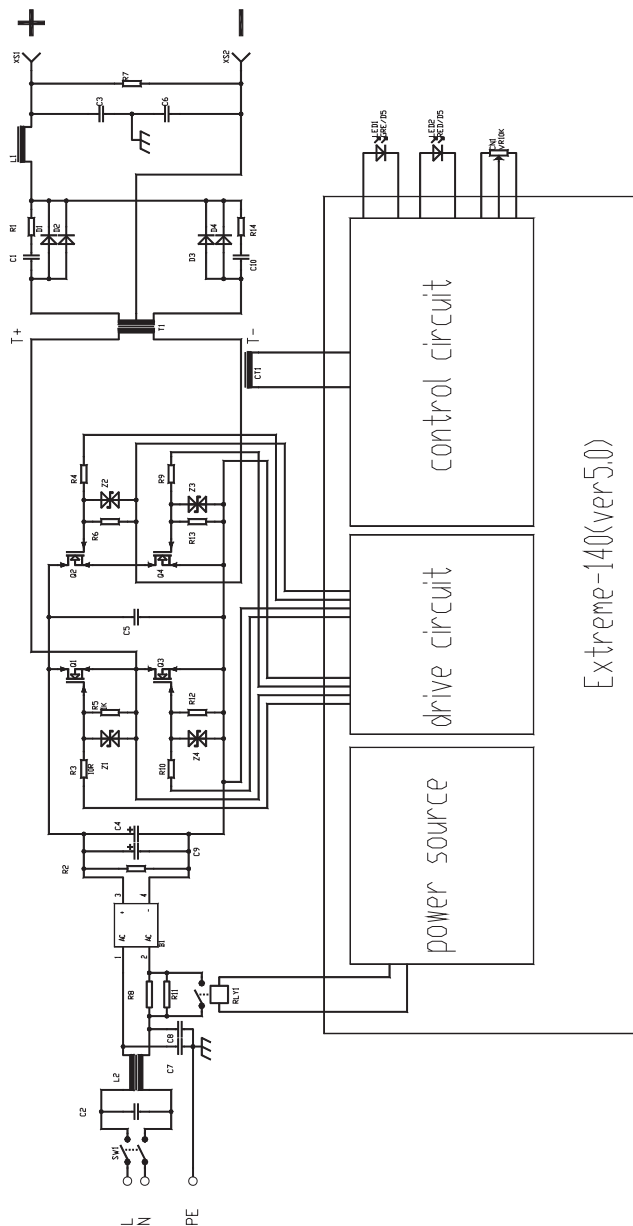

General Safety Information

1.1 Your Welding Environment

- Keep the environment you will be welding in free from flammable materials.
- Always keep a fire extinguisher accessible to your welding environment.
- Always have a qualified person install and operate this equipment.

- Make sure the area is clean, dry and ventilated. Do not operate the welder in humid, wet or poorly ventilated areas.
- Always have your welder maintained by a qualified technician in accordance with local, state and national codes.
- Always be aware of your work environment. Be sure to keep other

 Operating Instructions and Parts Manual

people, especially children, away from you while welding.

-Keep harmful arc rays shielded from the view of others.

-Mount the welder on a secure bench or cart that will keep the welder secure and prevent it from tipping over or falling.

1.2 Your Welder's Condition

-Check all cables, power cord and welding cable to be sure the insulation is not damaged. Always replace or repair damaged components before using the welder.

-Check all components to ensure they are clean and in good operating condition before use.

1.3 Use of Your Welder

▲ CAUTION

Do not operate the welder if the output cable, electrode, or any part of the system is wet. Do not immerse them in water. These components and the welder must be completely dry before attempting to use it.

-Follow the instructions in this manual.

-Keep welder in the off position when not in use.

-Connect ground lead as close to the area being welded as possible to ensure a good ground.

-Do not allow any body part to come in contact with the electrode if you are in contact with the material being welded, ground or electrode from another welder.

-Do not weld if you are in an awkward position. Always have a secure stance while welding to prevent accidents. Wear a safety harness if working above ground.

-Do not drape cables over or around your body.

-Wear a full coverage helmet with shade (see ANSI Z87.1 safety

standard) and safety glasses while welding.

-Wear proper gloves and protective clothing to prevent your skin from being exposed to hot metals, UV and IR rays.

-Do not overuse or overheat your welder. Allow proper cooling time between duty cycles.

-Always use this welder in the rated duty cycle to prevent excessive heat and failure.

1.4 Specific Areas of Danger, Caution or Warning



Electrical Shock

▲ WARNING

Electric arc welders can produce a shock that can cause injury or

death. Touching electrically live parts can cause fatal shocks and severe burns. While welding, all metal components connected to the unit are electrically hot. Poor ground connections are a hazard, so secure the ground lead before welding.

-Wear dry protective apparel: coat, shirt, gloves and insulated footwear.

-Insulate yourself from the work piece. Avoid contacting the work piece or ground.

- Do not attempt to repair or maintain the welder while the power is on.

-Inspect all cables and cords for any exposed wire and replace immediately.

-Use recommended replacement cables and cords.

-Always attach ground clamp to the work piece work table as close to the weld area as possible.

-Do not touch the electrode and the ground or grounded work piece at the same time.

-Do not use a welder to thaw frozen pipes.

Operating Instructions and Parts Manual

**Fumes and Gases****⚠ WARNING**

-Fumes emitted from the welding process displace clean air and can result in

injury or death.

-Do not breathe in fumes emitted by

the welding process. Make sure your breathing air is clean and safe.

-Work only in a well-ventilated area or use a ventilation device to remove welding fumes from the environment where you will be working.

-Do not weld on coated materials (galvanized, cadmium plated or containing zinc, mercury or barium). They will emit harmful fumes that are dangerous to breathe. If necessary use a ventilator, respirator with air supply or remove the coating from the material in the weld area.

-The fumes emitted from some metals when heated are extremely toxic. Refer to the material safety data sheet for the manufacturer's instructions.

-Do not weld near materials that will emit toxic fumes when heated. Vapors from cleaners, sprays and degreasers can be highly toxic when heated.

UV and IR Arc Rays**⚠ DANGER**

The welding arc produces ultraviolet (UV) and infrared (IR) rays

that can cause injury to your eyes and skin. Do not look at the welding arc without proper eye protection.

-Always use a helmet that covers your full face from the neck to top of head and to the back of each ear.

-Use a lens that meets ANSI standards and safety glasses. For welders under 160 Amps output, use

a shade 10 lens; for above 160 Amps, use a shade 12. Refer to the ANSI standard Z87.1 for more information.

-Cover all bare skin areas exposed to the arc with protective clothing and shoes. Flame-retardant cloth or leather shirts, coats, pants or

coveralls are available for protection.

-Use screens or other barriers to protect other people from the arc rays emitted from your welding.

-Warn people in your welding area when you are going to strike an arc so they can protect themselves.

Fire Hazards**⚠ WARNING**

Do not weld on containers or pipes that contain or have had flammable,

gaseous or liquid combustibles in them. Welding creates sparks and heat that can ignite flammable and

explosive materials.

-Do not operate any electric arc welder in areas where flammable or explosive materials are present.

-Remove all flammable materials within 35 feet of the welding arc. If removal is not possible, tightly cover them with fireproof covers.

-Take precautions to ensure that flying sparks do not cause fires or explosions in hidden areas, cracks or areas you cannot see.

-Keep a fire extinguisher close in the case of fire.

-Wear garments that are oil-free with no pockets or cuffs that will collect sparks.

-Do not have on your person any items that are combustible, such as lighters or matches.

-Keep work lead connected as close to the weld area as possible to

Operating Instructions and Parts Manual

prevent any unknown, unintended paths of electrical current from causing electrical shock and fire hazards.

**Hot Materials****▲ CAUTION**

Welded materials are hot and can cause severe burns if handled

improperly.

- Do not touch welded materials with bare hands.
- Do not touch electrode holder after welding until it has had time to cool down.

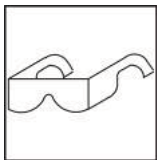
**Sparks/Flying Debris****▲ CAUTION**

Welding creates hot sparks that can cause injury. Chipping slag off welds creates flying debris.

- Wear protective apparel at all times: ANSI-approved safety glasses or shield, welder's hat and ear plugs to keep sparks out of ears and hair.

**Electromagnetic Field****▲ CAUTION**

-Electromagnetic fields can interfere with various electrical and electronic devices such as pacemakers.

- Consult your doctor before using any electric arc welder or cutting device
- Keep people with pacemakers away from your welding area when welding.
- Do not wrap cable around your body while welding.

Assembly

This unit is assembled when out of factory.

- Wrap welding cable and ground cable together whenever possible.
- Keep welding cable and ground cables on the same side of your body.

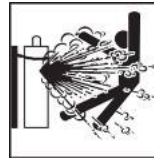
**Shielding Gas Cylinders Can Explode****▲ WARNING**

High pressure cylinders can explode if damaged, so treat them carefully.

- Never expose cylinders to high heat, sparks, open flames, mechanical shocks or arcs.
- Do not touch cylinder with welding cable.
- Do not weld on the cylinder.
- Always secure cylinder upright to a cart or stationary object.
- Keep cylinders away from welding or electrical circuits.
- Use the proper regulators, gas hose and fittings for the specific application.
- Do not look into the valve when opening it.
- Use protective cylinder cap whenever possible.

1.5 Proper Care, Maintenance And Repair**▲ DANGER**

- Always have power disconnected when working on internal components.
- Do not touch or handle PC board without being properly grounded with a wrist strap. Put PC board in static proof bag to move or ship.
- Do not put hands or fingers near moving parts such as fan.

Installation**1. Power requirement**

AC single phase 120v (110-120V), 60HZ fused with a 20amp time delayed fuse or circuit breaker is

Operating Instructions and Parts Manual

required. DO NOT OPERATE THIS UNIT if the ACTUAL power source voltage is less than 105 volts ac or greater than 132 volts ac.

▲ WARNING

- **High voltage danger from power source! Consult a qualified electrician for proper installation of receptacle. This welder must be grounded while in use to protect the operator from electrical shock.**
- **Do not remove grounding prong or alter the plug in any way. Do not use any adapters between the welder's power cord and the power source receptacle. Make sure the POWER switch is OFF when connecting your welder's power cord to a properly grounded 120Vac, 60Hz, single phase, 20 amp power source.**

2. Extension cord

During normal use an extension cord is not necessary. It is strongly recommended that an extension cord should not be used because of the voltage drop they produce. This drop in voltage can affect the performance of the welder. If you need to use an extension cord it must be a #12 gauge cord at the smallest.

-Do not use an extension cord over 25 ft. in length.

3. Setting up the work piece

3.1 Welding positions

There are two basic positions, for welding: Flat and Horizontal. Flat welding is generally easier, faster, and allows for better penetration. If possible, the work piece should be positioned so that the bead will run on a flat surface.

3.2 Preparing the Joint

Before welding, the surface of work piece needs to be free of dirt, rust, scale, oil or paint. Or it will create

brittle and porous weld. If the base metal pieces to be joined are thick or heavy, it may be necessary to bevel the edges with a metal grinder. The correct bevel should be around 60 degrees. See following picture:

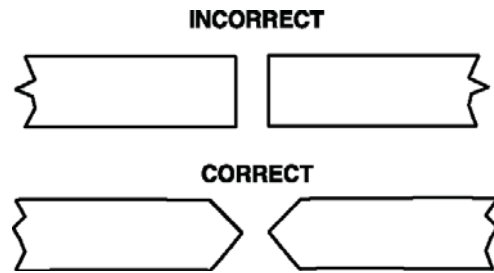

Based on different welding position, there are different welding joint, see following images for more information

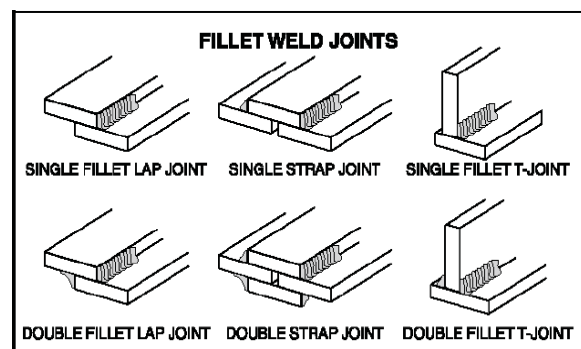
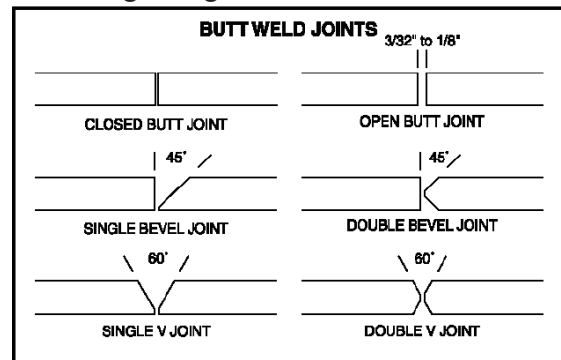

4. Ground clamp connection

Clear any dirt, rust, scale, oil or paint on the ground clamp. Make certain you have a good solid ground connection. A poor connection at the ground clamp will waste power and heat. Make sure the ground clamp touches the metal.

Operating Instructions and Parts Manual

5. Electrode

The welding electrode is a rod coated with a layer of flux. When welding, electrical current flows between the electrode (rod) and the grounded metal work piece. The intense heat of the arc between the rod and the grounded metal melts the electrode and the flux. The most popular electrodes are:

- E6011 60,000 PSI tensile strength deep penetrating applications.
- E6013 60,000 PSI tensile strength used for poor fit up applications
- E7014 70,000 PSI tensile strength used for high deposition and fast travel speeds with light penetration
- E7018 70,000 PSI tensile strength,

Used for out of position and tacking.

6. Selecting the proper electrode

There is no golden rule that determine the exact rod or heat setting required for every situation. The type and thickness of metal and the position of the work piece determine the electrode type and the amount of heat needed in the welding process. Heavier and thicker metals required more amperage. It is best to practice your welds on scrap metal which matches the metal you intend to work with to determine correct heat setting and electrode choice. See following some helpful trouble shooting tips to determine if you are using a correct electrode

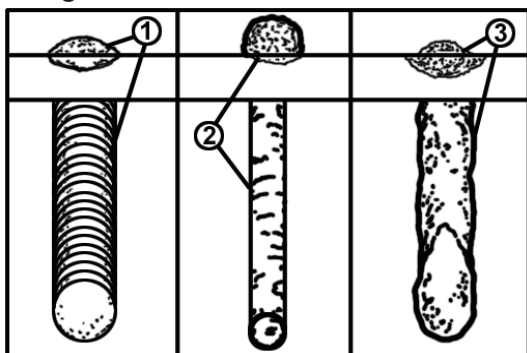

1. When proper rod is used:
 - a. The bead will lay smoothly over the work without ragged edges
 - b. The base metal puddle will be as deep as the bead that rises above it
 - c. The welding operation will make a crackling sound similar to the sound of eggs frying
2. When a rod too small is used:
 - a. The bead will be high and irregular
 - b. The arc will be difficult to maintain
3. When the rod is too large:
 - a. The arc will burn through light metals
 - b. The bead will undercut the work
 - c. The bead will be flat and porous
 - d. Rod may be freeze or stick to work piece

Note: Rate of travel over the work also affects the weld. To ensure proper penetration and enough deposit of rod, the arc must be moved slowly and evenly along the weld seam.

Operation**1. Setting the amperage control**

The welder has an infinite output current control. It is capable of welding with 1/16" and 5/64" and 3/32" electrodes.

There is no golden rule that determines the exact amperage required for every situation. It is best to practice your welds on scrap metal which matches the metals you intend to work with to determine correct setting for your job. The electrode type and the thickness of the work piece metal determine the amount of heat needed in the welding process. Heavier and thicker metals require more voltage (amperage), whereas

Operating Instructions and Parts Manual

lighter and thinner metals require less voltage (amperage).

2. Welding techniques

The best way to teach yourself how to weld is with short periods of practice at regular intervals. All practice welds should be done on scrap metal that can be discarded. Do not attempt to make any repairs on valuable equipment until you have satisfied yourself that your practice welds are of good appearance and free of slag or gas inclusions.

2.1 Holding the electrode

The best way to grip the electrode holder is the way that feels most comfortable to you. To Position the Electrode to the work piece when striking the initial arc it may be necessary to hold the electrode perpendicular to the work piece. Once the arc is started the angle of the electrode in relation to the work piece should be between 10 and 30 degrees. This will allow for good penetration, with minimal spatter.

2.2 Striking the arc

▲ WARNING

EXPOSURE TO A WELDING ARC IS EXTREMELY HARMFUL TO THE EYES AND SKIN.

- **Never strike an arc or begin welding until you have adequate protection.**
- **Wear flameproof welding gloves, heavy long-sleeved shirt, cuffless trousers, high-topped shoes and a welding helmet or shield.**

Scratch the work piece with the end of electrode to start arc and then raise it quickly about 1/8 inch gap between the rod and the work piece. See following picture:

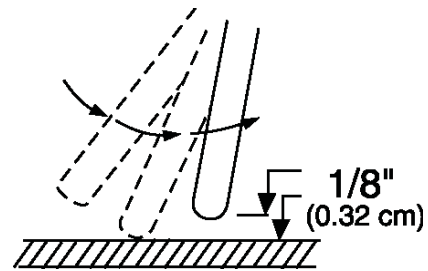

It is important that the gap be maintained during the welding process and it should be neither too wide or too narrow. If too narrow, the rod will stick to the work piece. If too wide, the arc will be extinguished. It needs much practice to maintain the gap. Beginners may usually get sticking or arc extinguishing. When the rod sticks to the work piece, gently rock it back and forth to make them separate. If not, the circuit is short connection, and it will overload the welder.

A good arc is accompanied by a crisp, cracking sound. The sound is similar to that made by eggs frying. To lay a weld bead, only 2 movements are required; downward and in the direction the weld is to be laid, as in following figure:

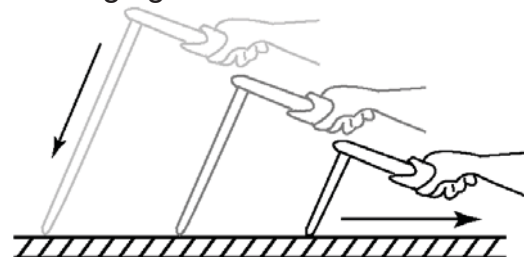

2.3 Types of weld bead

The following paragraphs discuss the most commonly used arc welding beads.

The stringer bead Formed by traveling with the electrode in a straight line while keeping it centered over the weld joint.

Operating Instructions and Parts Manual

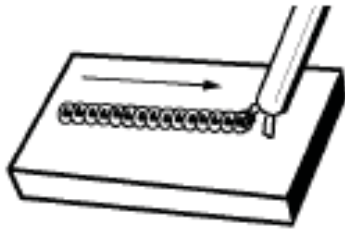

The weave bead Used when you want to deposit metal over a wider space than would be possible with a stringer bead. It is made by weaving from side to side while moving with the electrode. It is best to hesitate momentarily at each side before weaving back the other way to improve penetration.

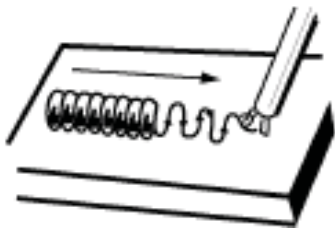

2.4 Welding position

Flat position is the easiest of the welding positions and is most commonly used. It is best if you can weld in the flat position if at all possible as good results are easier to achieve.

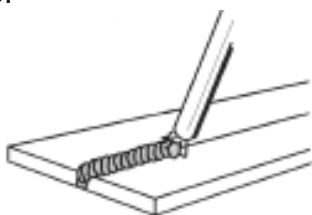

The horizontal position is performed very much the same as the flat weld except that the angle is different such that the electrode, and therefore the arc force, is directed more toward the metal above the weld joint. This more direct angle helps prevent the weld puddle from running downward while still allowing slow enough travel speed to achieve good penetration. A good starting point for your electrode angle is about

30 degrees DOWN from being perpendicular to the work piece.



2.5 Judge a good weld bead

When the trick of establishing and holding an arc has been learned, the next step is learning how to run a good bead. The first attempts in practice will probably fall short of acceptable weld beads. Too long of an arc will be held or the travel speed will vary from slow to fast (see following)

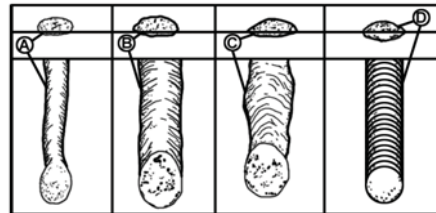

- A. Weld speed is too fast.
- B. Weld speed is too slow.
- C. Arc is too long.
- D. Ideal weld.

A solid weld bead requires that the electrode be moved slowly and steadily along the weld seam. Moving the electrode rapidly or erratically will prevent proper fusion or create a lumpy, uneven bead. To prevent ELECTRIC SHOCK, do not perform any welding while standing, kneeling, or lying directly on the grounded work.

2.6 Finish the bead

As the coating on the outside of the electrode burns off, it forms an envelope of protective gasses around the weld. This prevents air from reaching the molten metal and creating an undesirable chemical reaction. The burning coating, however, forms slag. The slag

Operating Instructions and Parts Manual

formation appears as an accumulation of dirty metal scale on the finished weld. Slag should be removed by striking the weld with a chipping hammer.

▲ WARNING***PEENING THE SLAG FROM A WELD JOINT CAUSES SMALL CHIPS OF METAL TO FLY THROUGH THE AIR***

- *Metallic chips flying through the air can cause eye injury or injury to other parts of the head, hands or exposed portions of the body.*
- *Wear goggles or eye glasses with side shields and protect the hands and other exposed parts of the body with protective garments, or if possible, work with a shield between the body and the work piece.*

The intense heat produced at the arc sets up strains in the metal joined by welding. Peening the weld not only removes the scale left behind in the welding but relieves the internal strains developed by the heating and cooling process. With the hammer/brush after it is cooled.

Maintenance

The welder needs regular maintenance as following: Periodically clean dust, dirt, grease, etc. from your welder. Every six months, or as necessary, remove the cover panel from the welder and air-blow any dust and dirt that may have accumulated inside the welder.

Replace power cord, ground cable, ground clamp, or electrode assembly when damaged or worn.

MINOR AND ROUTINE MAINTENANCE

Store in a clean dry

facility free from corrosive gas, excess dust and high humidity. Temperature range from 10° F – 120°F and the relative humidity not more than 90%.

When transporting or storing the welder after use, it is recommended to repack the product as it was received for protection. (Cleaning is required before storage and you must seal the plastic bag in the box for storage

Trouble shooting Chart

No.	Breakdown	Analysis	Solutions
1	Yellow Indicator is on	Poor ventilation leads to over-heat protection	Improve ventilation
		Internal temperature is too high	Will automatically recover when the temperature lowers.
		Using over the rated duty-cycle	Will automatically recover when the temperature lowers.
2	The adjustment knob on the front panel didn't work	Potentiometer broken (current regulation)	Replace the potentiometer.
3	Cooling Fan not working or turning very slowly	Switch broken	Replace the switch
		Fan broken	Replace or repair the fan
		Wire broken or fallen off	Check connections
4	No no-load voltage	Over voltage, under voltage	See No. 1
		Welder getting overheated	See No. 1
		Switch broken	Replace the switch

Operating Instructions and Parts Manual

5	Electrode Holder and Cable getting hot; “+” “-” polar sockets becoming hot	Electrode Holder’s capacity is too small;	Replace with a higher Amperage Holder
		Cable is of small size	Replace it with another one in conformity with the requirement
		Socket loosen	Remove the oxide coating and tighten it
		High resistance between the electrode holder and the cable	
6	Power source tripping	Resume power over a long period of time (more than two days)	Not a failure. Trip caused by the main power filter’s capacity charging. Switch on the main power source.
		In the process of welding	Contact us
7	Others		Contact us

Operating Instructions and Parts Manual

Warranty**LIMITED ONE-YEAR WARRANTY**

Should this product fail to perform satisfactorily due to a defect or poor workmanship within ONE YEAR from the date of purchase, return it to the place of purchase and it will be replaced, free of charge. Incidental or consequential damages are excluded from this warranty.

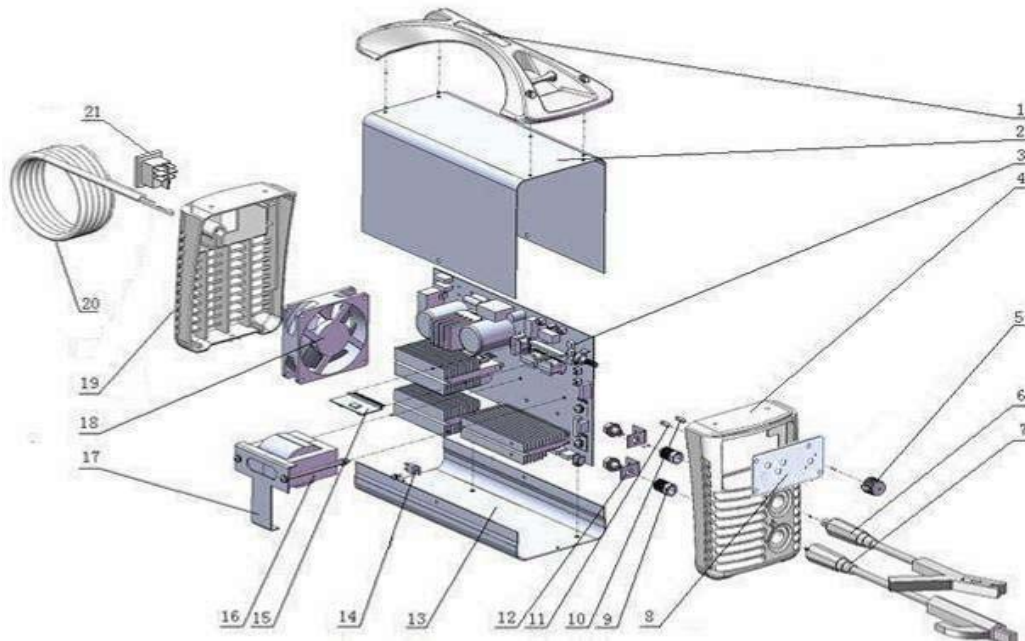
**Repair Parts List**

Reference number	Description	Part number	Qty
1	Handle	2.05.08.118	1
2	Enclosure	1.1.01.01.0148	1
3	PCB	1.1.05.02.0288	1
4	Plastic front panel	2.05.05.701	1
5	Switch (RoHS)	2.07.11.017	1
6	"-" output cable	1.2.08.02.2108	1
7	"+" output cable	1.2.08.01.1604	1
8	Front assembly	1.2.01.01.3645	1

Operating Instructions and Parts Manual

9	Dins connector (copper) (ROHS)	2.07.57.147	2
10	Thermal protection Indicating light	1.2.07.02.3010	1
11	Power Indicating light	1.2.07.02.3011	1
12	Output fixed board	1.1.03.04.0137	2
13	Bottom panel	1.1.01.04.0340	1
14	Temperature relay	1.2.07.02.3008	1
15	Driver module (ROHS)	1.1.05.03.0025	1
16	Intermediate- frequency transformer (120V)	2.07.25.819	1
17	Transformer fixed board	1.1.02.01.0750	1
18	Fan wiring harness (ROHS)	1.2.07.02.0614	1
19	Plastic back panel	2.05.05.702	1
20	Powerline with plug (RoHS)	2.03.05.133	1
21	Wave switch (ROHS)	2.07.80.213	1

Other Safety and Standards Information

This manual is designed to inform the operator of safety and general use of this model only. For further information about welding safety refer to the following standards and comply with them where applicable.

- **ANSI Standard Z49.1 — SAFETY IN WELDING AND CUTTING** obtainable from: American Welding Society 550 NW Le Jeune Road, Miami, FL 33126
Tel. (800) 443-9353
Fax (305) 443-7559
www.amweld.org or www.aws.org

Operating Instructions and Parts Manual

- **ANSI Standard Z87.1** — SAFE PRACTICE FOR OCCUPATION AND EDUCATIONAL EYE AND FACE PROTECTION

Obtainable from: American National Standards Institute (ANSI) 11 West 42nd St. New York, NY 10036
Tel. (212) 642-4900
Fax (212) 398-0023 www.ansi.org

- **NFPA Standard 51B** — CUTTING AND WELDING PROCESS obtainable from:

National Fire Protection Association, 1 Batterymarch Park, P.O. Box 9101 Quincy, MA 02269-9101
Tel. (617) 770-3000
Fax (617) 770-0700 www.nfpa.org

- **OSHA Standard 29 CFR**, Part 1910, Subpart Q. —WELDING, CUTTING AND BRAZING obtainable from your state OSHA office or from: U. S. Dept. of Labor OSHA, Office of Public Affairs Room N3647, 200 Constitution Ave. NW Washington, DC 20210 www.osha.gov

- **CSA Standard W117.2** — Code for SAFETY IN WELDING AND CUTTING

Obtainable from: Canadian Standards Association, 178 Rexdale Blvd., Etobicoke, Ontario M9W 1R3
www.csa.ca

- **American Welding Society Standard A6.0** —WELDING AND CUTTING CONTAINERS WHICH HAVE HELD COMBUSTIBLES

Obtainable from: American Welding Society, 550 NW Le Jeune Road Miami, FL 33126
Tel. (800) 443-9353
Fax (305) 443-7559
www.amweld.org or www.aws.org